

# Solenoid valve(3/2 way)

## 3V100 Series

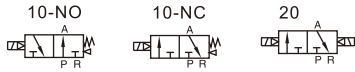

### Symbol



### Product feature

1. Pilot-oriented mode: Internal pilot or external pilot.
2. Structure in sliding column mode: good tightness and sensitive reaction.
3. Double control solenoid valves have memory function.
4. Internal hole adopts special processing technology which has little attrition friction, low start pressure and long service life.
5. No need to add oil for lubrication.
6. Affiliated manual devices are equipped to facilitate installation and debugging.
7. Several standard voltage grades are optional.
8. Integrate with the manifold to save installation space.

### Specification

Model	3V110-M5	3V120-M5	3V110-06	3V120-06
Fluid	Air(to be filtered by 40 μm filter element)			
Acting	Internal pilot or external pilot			
Port size [Note1]	M5		1/8"	
Orifice size	5.5mm <sup>2</sup> (Cv=0.31)		12.0mm <sup>2</sup> (Cv=0.67)	
Valve type	3 port 2 position			
Lubrication [Note2]	Not required			
Operating pressure	0.15~0.8MPa(21~114psi)			
Proof pressure	1.2MPa(175psi)			
Temperature	-20~70°C			
Material of body	Aluminum alloy			

[Note 1] PT thread, G thread and NPT thread are available.

[Note 2] Once lubricated air is used, continue with same medium to optimise valve life span. Lubricants like ISO VG32 or equivalent are recommended.

### Coil specification

Item	specification				
Standard voltage	AC220V	AC110V	AC24V	DC24V	DC12V
Scope of voltage	AC: ± 15% DC: ± 10%				
Power consumption	3.5VA	3.5VA	4.0VA	2.5W	2.5W
Protection	IP65(DIN40050)				
Temperature classification	B Class				
Electrical entry	Terminal, Grommet				
Activating time	0.05 sec and below				
Max. frequency [Note 1]	5 cycle/sec				

[Note 1] The maximum actuation frequency is in the no-load state.

### Ordering code

3V 1 10 06 NO A □ □



① Model	② Code	③ Valve type	④ Port size	⑤ Acting type	⑥ Standard voltage	⑦ Electrical entry	⑧ Thread type	
3V:Solenoid valve (3/2 way)	1: 100 Series	10: Single solenoid	M5: M5 06: 1/8"	NC: Normally closed NO: Normally opened	A: AC220V B: DC24V C: AC110V E: AC24V F: DC12V	Blank: Terminal I: Grommet	M5	1/8"
		20: Double solenoid		No this code			No this code	Blank: PT G: G T: NPT

Please refer to 75 for manifold specification and the order way.

### Flow chart

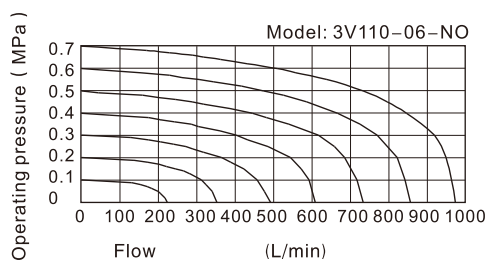

# Solenoid valve(3/2 way)

## 3V100 Series

### Inner structure

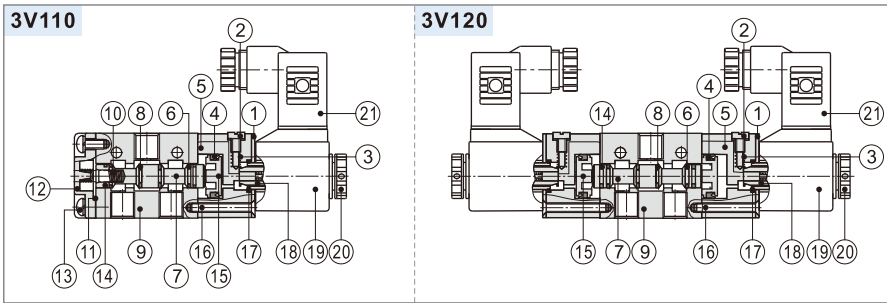

No.	Item	No.	Item	No.	Item
1	Fixed plate	8	O-ring	15	Piston
2	Manual override	9	Body	16	Pilot screw
3	Override spring	10	Spool spring	17	O-ring
4	Piston O-ring	11	Bottom cover gasket	18	Armature
5	Pilot body	12	Bottom cover	19	Coil
6	Spool packing	13	Screw	20	Coil net
7	Spool	14	Wear ring	21	Connector

### Dimensions

#### 3V110(Terminal)

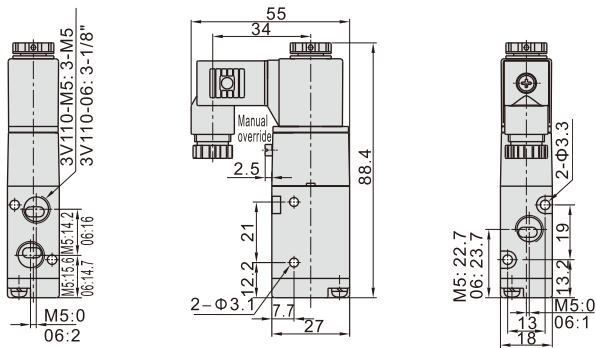

#### 3V110(Grommet)

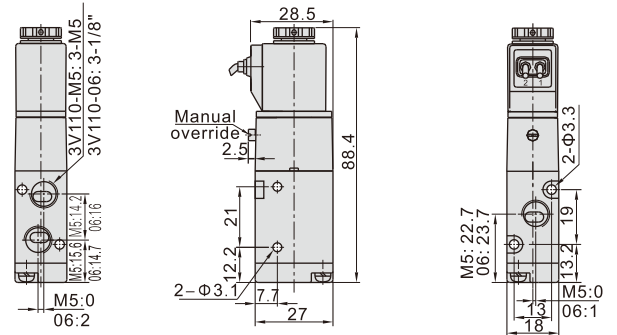

#### 3V120(Terminal)

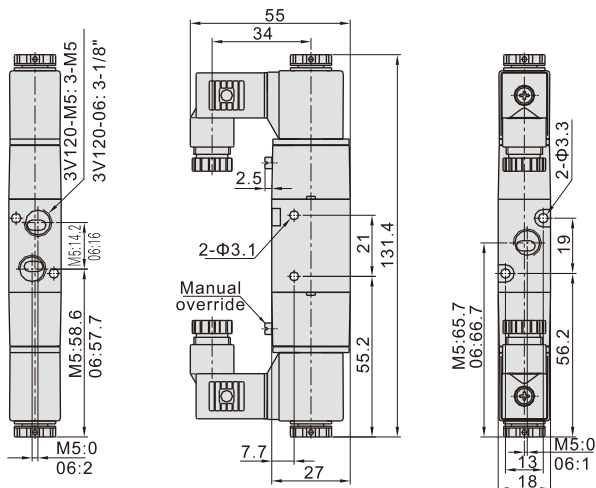

#### 3V120(Grommet)

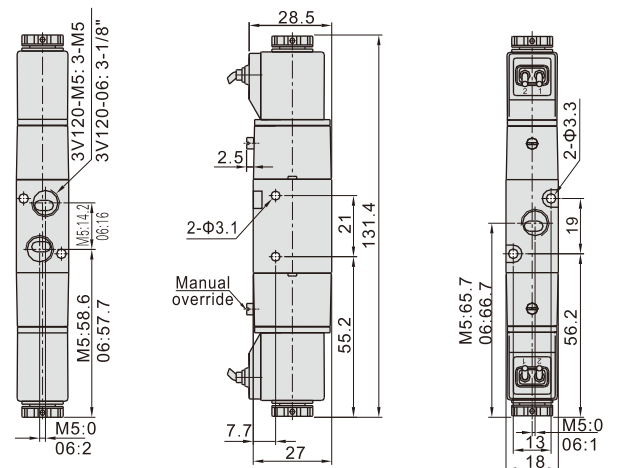

# Solenoid valve(3/2 way)

## 3V200 Series



### Symbol

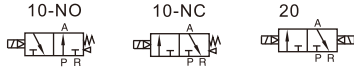

### Product feature

1. Pilot-oriented mode: Internal pilot or external pilot.
2. Structure in sliding column mode: good tightness and sensitive reaction.
3. Double control solenoid valves have memory function.
4. Internal hole adopts special processing technology which has little attrition friction, low start pressure and long service life.
5. No need to add oil for lubrication.
6. Affiliated manual devices are equipped to facilitate installation and debugging.
7. Several standard voltage grades are optional.
8. Integrate with the manifold to save installation space.

### Ordering code

3V 2 10 08 NO A □ □  
 ① ② ③ ④ ⑤ ⑥ ⑦ ⑧

① Model	② Code	③ Valve type	④ Port size	⑤ Acting type	⑥ Standard voltage	⑦ Electrical entry	⑧ Thread type
3V: Solenoid valve (3/2 way)	2: 200 Series	10: Single solenoid 20: Double solenoid	06: 1/8" 08: 1/4"	NC: Normally closed NO: Normally opened  No this code	A: AC220V B: DC24V C: AC110V E: AC24V F: DC12V	Blank: Terminal I: Grommet	Blank: PT G: G T: NPT

Please refer to 75 for manifold specification and the order way.

### Flow chart

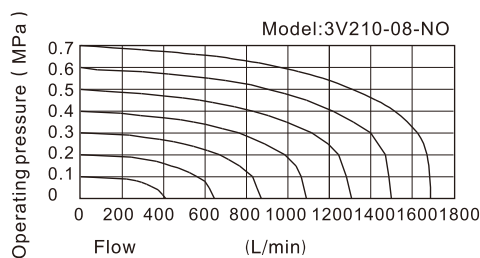

### Specification

Model	3V210-06	3V220-06	3V210-08	3V220-08
Fluid	Air (to be filtered by 40 μm filter element)			
Acting	Internal pilot or external pilot			
Port size [Note 1]	In=Out=1/8"		In=Out=1/4"	
Orifice size	14.0mm <sup>2</sup> (Cv=0.78)		16.0mm <sup>2</sup> (Cv=0.89)	
Valve type	3 port 2 position			
Lubrication [Note 2]	Not required			
Operating pressure	0.15~0.8MPa(21~114psi)			
Proof pressure	1.2MPa(175psi)			
Temperature	-20~70°C			
Material of body	Aluminum alloy			

[Note 1] PT thread, G thread and NPT thread are available.

[Note 2] Once lubricated air is used, continue with same medium to optimise valve life span. Lubricants like ISO VG32 or equivalent are recommended.

### Coil specification

Item	specification				
Standard voltage	AC220V	AC110V	AC24V	DC24V	DC12V
Scope of voltage	AC: ± 15% DC: ± 10%				
Power consumption	4.5VA	4.5VA	5.0VA	3.0W	3.0W
Protection	IP65(DIN40050)				
Temperature classification	B Class				
Electrical entry	Terminal, Grommet				
Activating time	0.05 sec and below				
Max. frequency [Note 1]	5 cycle/sec				

[Note 1] The maximum actuation frequency is in the no-load state.

# Solenoid valve(3/2 way)

## 3V200 Series

### Inner structure

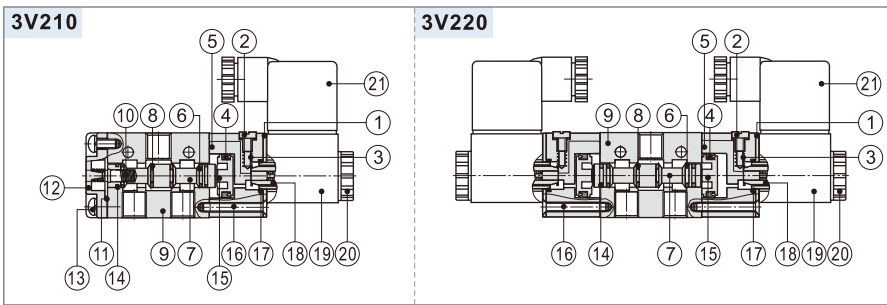

No.	Item	No.	Item	No.	Item
1	Fixed plate	8	O-ring	15	Piston
2	Manual override	9	Body	16	Pilot screw
3	Override spring	10	Spool spring	17	O-ring
4	Piston O-ring	11	Bottom cover gasket	18	Armature
5	Pilot body	12	Bottom cover	19	Coil
6	Spool packing	13	Screw	20	Coil net
7	Spool	14	Wear ring	21	Connector

### Dimensions

#### 3V210(Terminal)

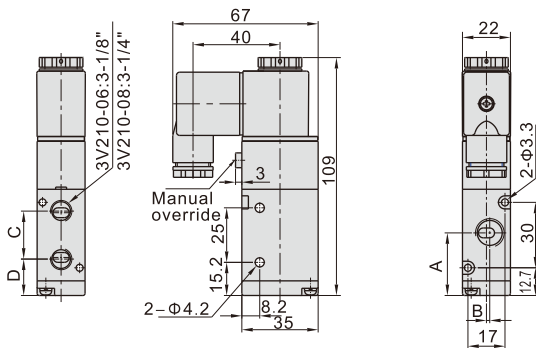

Item\Model	3V210-06	3V210-08
A	27.7	28.7
B	0	1.5
C	22	22.5
D	16.7	16.5

#### 3V210(Grommet)

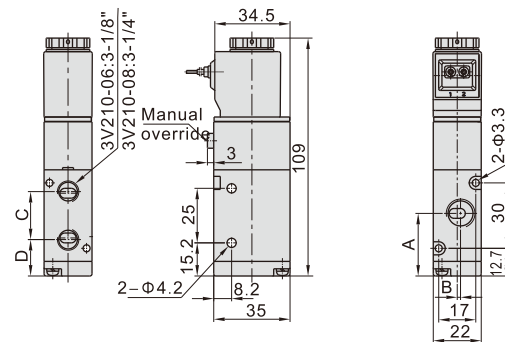

Item\Model	3V210-06	3V210-08
A	27.7	28.7
B	0	1.5
C	22	22.5
D	16.7	16.5

#### 3V220(Terminal)

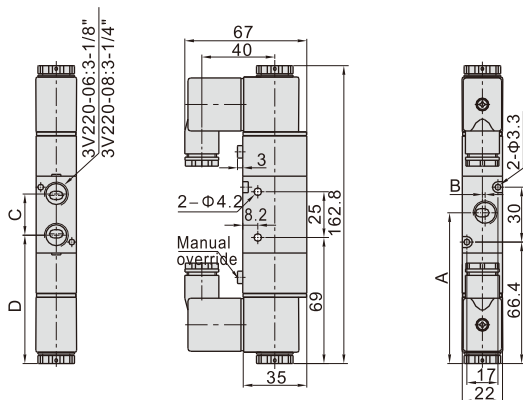

Item\Model	3V220-06	3V220-08
A	81.4	82.4
B	0	1.5
C	22	22.5
D	70.4	70.2

#### 3V220(Grommet)

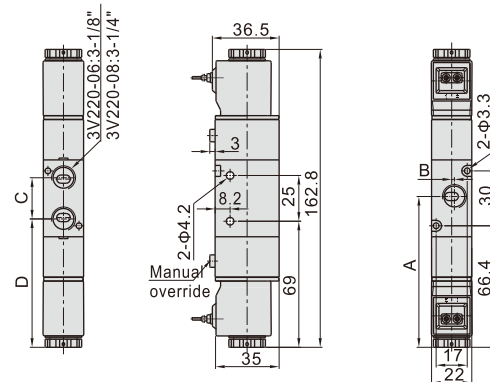

Item\Model	3V220-06	3V220-08
A	81.4	82.4
B	0	1.5
C	22	22.5
D	70.4	70.2

# Solenoid valve(3/2 way)

## 3V300 Series



### Symbol

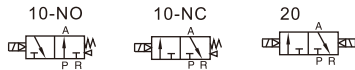

### Product feature

1. Pilot-oriented mode: Internal pilot or external pilot.
2. Structure in sliding column mode: good tightness and sensitive reaction.
3. Double control solenoid valves have memory function.
4. Internal hole adopts special processing technology which has little attrition friction, low start pressure and long service life.
5. No need to add oil for lubrication.
6. Affiliated manual devices are equipped to facilitate installation and debugging.
7. Several standard voltage grades are optional.
8. Integrate with the manifold to save installation space.

### Ordering code

3V 3 10 10 NO A □ □							
① Model	② Code	③ Valve type	④ Port size	⑤ Acting type	⑥ Standard voltage	⑦ Electrical entry	⑧ Thread type
3V: Solenoid valve (3/2 way)	3: 300 Series	10: Single solenoid	08: 1/4" 10: 3/8"	NC: Normally closed NO: Normally opened	A: AC220V B: DC24V C: AC110V E: AC24V F: DC12V	Blank: Terminal I: Grommet	Blank: PT G: G T: NPT
		20: Double solenoid		No this code			

Please refer to 75 for manifold specification and the order way.

### Flow chart

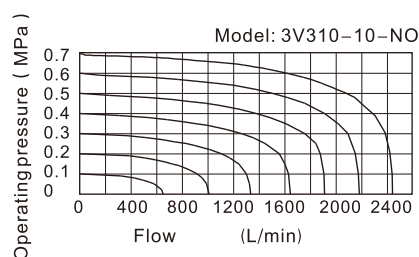

### Specification

Model	3V310-08	3V320-08	3V310-10	3V320-10
Fluid	Air(to be filtered by 40 μ m filter element)			
Acting	Internal pilot or external pilot			
Port size [Note 1]	In=Out=1/4"		In=Out=3/8"	
Orifice size	25.0mm <sup>2</sup> (Cv=1.39)		30.0mm <sup>2</sup> (Cv=1.67)	
Valve type	3 port 2 position			
Lubrication [Note2]	Not required			
Operating pressure	0.15~0.8MPa(21~114psi)			
Proof pressure	1.2MPa(175psi)			
Temperature	-20~70°C			
Material of body	Aluminum alloy			

[Note1] PT thread, G thread and NPT thread are available.

[Note2] Once lubricated air is used, continue with same medium to optimise valve life span. Lubricants like ISO VG32 or equivalent are recommended.

### Coil specification

Item	specification				
Standard voltage	AC220V	AC110V	AC24V	DC24V	DC12V
Scope of voltage	AC: ± 15% DC: ± 10%				
Power consumption	4.5VA	4.5VA	5.0VA	3.0W	3.0W
Protection	IP65(DIN40050)				
Temperature classification	B Class				
Electrical entry	Terminal, Grommet				
Activating time	0.05 sec and below				
Max. frequency [Note1]	5 cycle/sec				

[Note1] The maximum actuation frequency is in the no-load state.

# Solenoid valve(3/2 way)

## 3V300 Series

### Inner structure

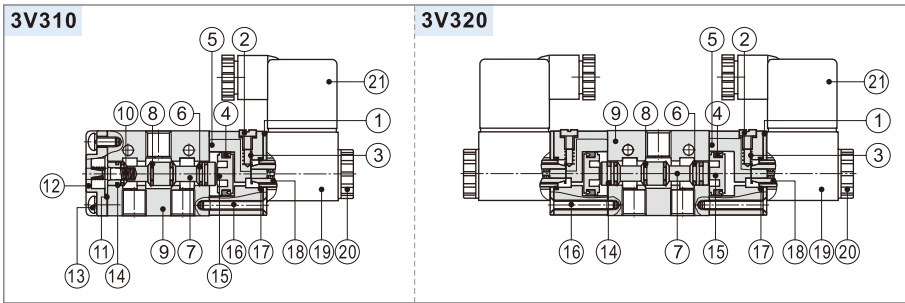

No.	Item	No.	Item	No.	Item
1	Fixed plate	8	O-ring	15	Piston
2	Manual override	9	Body	16	Pilot screw
3	Override spring	10	Spool spring	17	O-ring
4	Piston O-ring	11	Bottom cover gasket	18	Armature
5	Pilot body	12	Bottom cover	19	Coil
6	Spool packing	13	Screw	20	Coil net
7	Spool	14	Wear ring	21	Connector

### Dimensions

#### 3V310(Terminal)

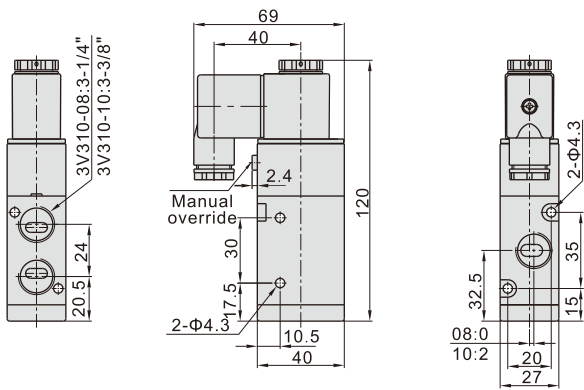

#### 3V310(Grommet)

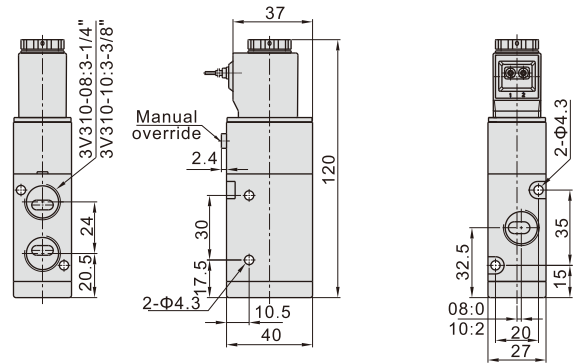

#### 3V320(Terminal)

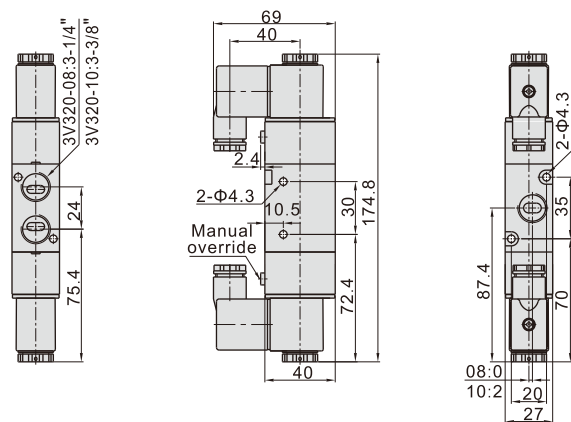

#### 3V320(Grommet)

